

MULTIZONE SYSTEM FOR DETECTION OF GAS LEAKS, CARBON MONOXIDE OR COMBUSTION FUMES

RFG 100

- Power supply 220/240 V ac and/or 12 V dc
- Constructed in 19" racks with IP 20 protection
- Option of using sensors for detecting gas, CO or combustion fumes
- Alarm threshold: 0.3% combustible gas and 0.05% CO in air
- Two SPDT voltage-free output contacts
- Possibility of controlling gas safety shut-off valves N.O. or N.C.

APPLICATION

The RFG 100 multizone system makes it possible to centralise the detection and control of combustible gas, carbon monoxide or combustion fumes in large industrial or non-industrial buildings (laboratories, workshops, garages, canteens, etc.) where numerous monitoring points are required.

RFG 100 consists of:

- One or more CRM 284 racks for housing all the electronic units.
- One AGS 013 central unit for each rack: this receives the alarm signals from the detector units, switches on the external alarms and activates the safety systems.
- One AGS 012 detector unit for each zone: suitable for detecting gas leaks or concentrations of carbon monoxide according to the type of sensor used.
- Or:
- One AGS 015 detector unit for each zone: suitable for detecting combustion fumes.
- One monitoring sensor for each zone: detects the presence of combustible gas or carbon monoxide or combustion fumes according to the type used.
- Mounting accessories.

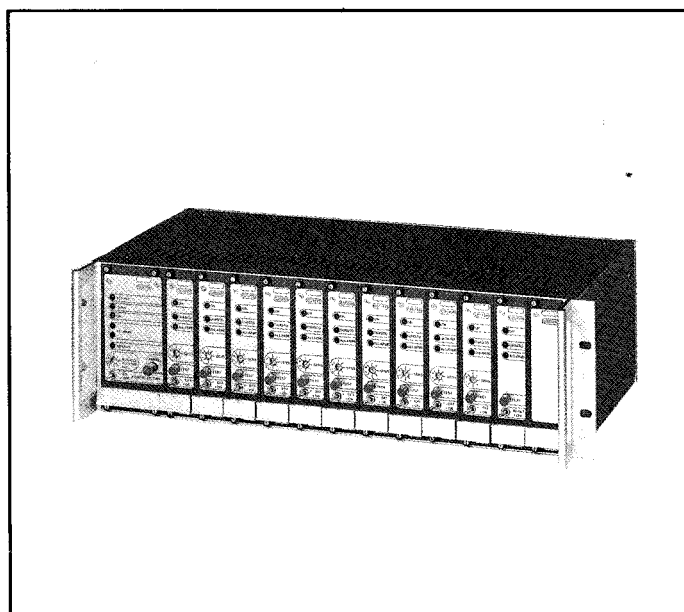

TYPICAL INSTALLATION

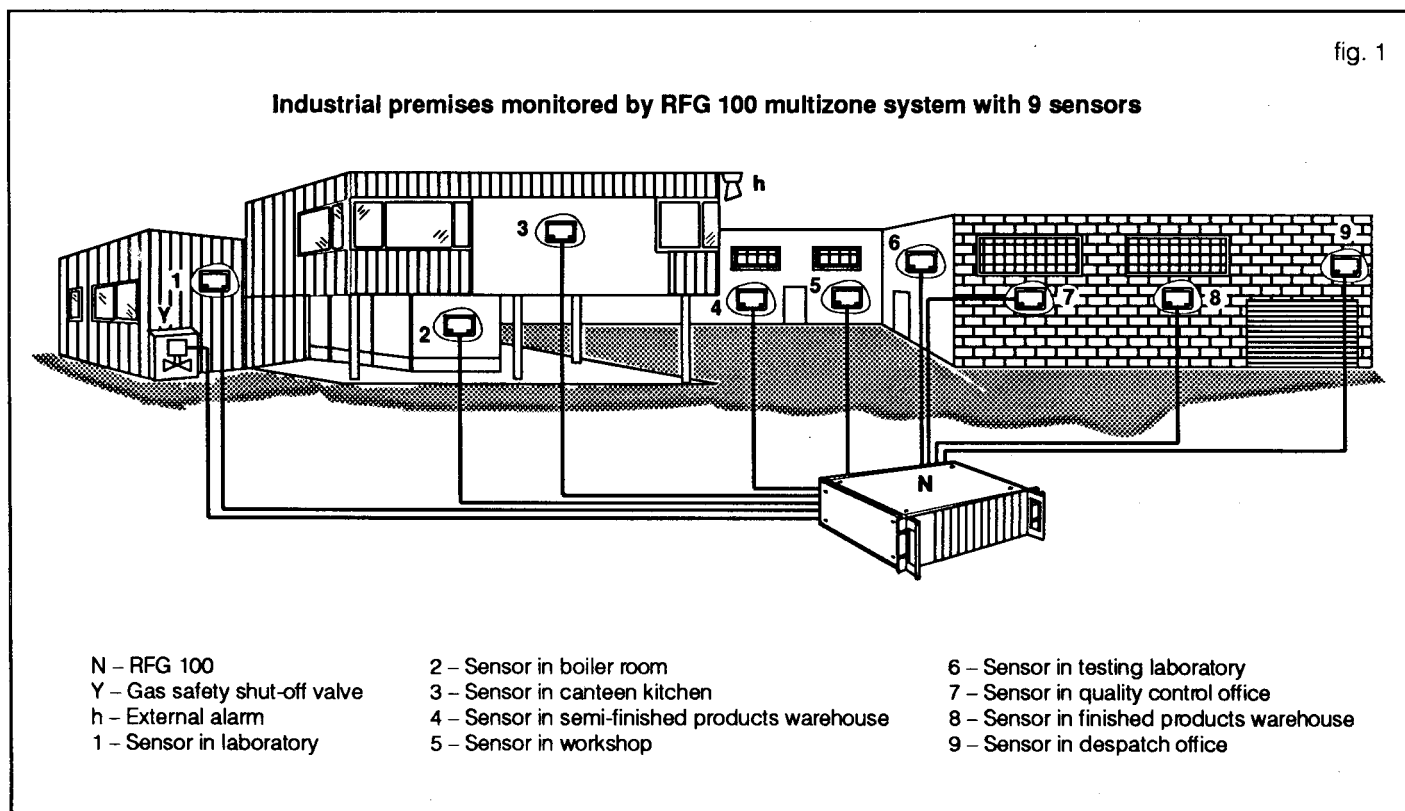

RACK

Code	Width	Maximum capacity
CRM 284	84 TE	1 AGS 013 central unit + 12 AGS 012 or AGS 015 detector units

ELECTRONIC UNITS

Code	Width	Description
AGS 013	12 TE	Central alarm unit (1 for each rack)
AGS 012	6 TE	Combustible gas or CO detector unit (1 for each zone)
AGS 015	6 TE	Combustion fumes detector unit (1 for each zone)

MONITORING SENSORS (1 FOR EACH ZONE)

Code	Application	Description	n° x unit	Protection	Sens. element
SGR 300	Comb. gas	For industrial premises	1	IP 44	TGS 813
SGR 301	CO	For industrial premises	1	IP 44	TGS 812
SAR 300	Comb. gas	Explosion-proof	1	EEx d	TGS 813
SAR 301	CO	Explosion-proof	1	EEx d	TGS 812
RFI 308	Comb. fumes	For industrial and non-industrial premises	1 to 4	IP 30	Photodiode

ACCESSORIES

Code	Width	Description
AGS 014 PLM 841	6 TE	Blanking plate for unused positions 2 bezels to cover cut-out for panel mounting of CRM 284

OPERATION

When the system is switched on it does not activate the alarms for the period necessary for the sensors to become stabilised. After this period (1.5 to 2 minutes) the lighting of the READY LED (fig.2a .6) indicates that the central unit AGS 013 is ready to give the alarm.

DETECTION OF COMBUSTIBLE GAS OR CO

The monitoring sensors S.. 300 or S.. 301 continuously analyse the surrounding air and transmit to their own detector unit AGS 012 a signal whose voltage is proportional to the concentration level of combustible gas or carbon monoxide present in the air. When the signal exceeds the admitted level, the detector unit enters the alarm state and transmits an order to central unit AGS 013 which, at the end of the alarm delay period (fig.2a .7) proceeds to:

– Signal the alarm state by means of the internal buzzer and the lighting of LEDs on the facia (fig.2a .5).

– Activate the external alarms relay and the operational relay.

The alarm threshold is equal to a concentration of 0.3% of combustible gas in the air, and 0.05% of carbon monoxide. These concentrations are well below those which can render the gas-air mixture explosive or dangerous for the human body, so that, when the alarm is given, it is possible to take action under conditions of maximum safety.

The alarm threshold can be adjusted slightly, up or down, in respect of the base level (level 0) to adapt it to special requirements or to features of the premises to be monitored (fig.2b .14). If a high sensitivity is required, so that the alarm is given at a low concentration, the potentiometer is turned towards +; if, on the other hand, there are conditions in the premises which tend to set off the alarm unnecessarily, the sensitivity should be reduced by turning the potentiometer towards -. In any event, the alarm threshold remains well below the danger levels.

FIRE PROTECTION

The RFI 308 sensors do not only analyse the surrounding air but also establish the alarm level and in the event that this is exceeded transmit a signal of the On-Off type to their own AGS 015 detector unit which enters the alarm state and sends the order to the AGS 013 central unit.

ALARM LEDS

When the detector unit enters the alarm state the Alarm LED (fig.2b .13 and fig.2c .13) lights.

When the central unit enters the alarm state the two Alarm LEDs on the facia (fig.2a .5) start flashing and the internal buzzer sounds. An operational relay with SPDT contacts permits the control of a gas safety shut-off valve or a fan for aeration. An output relay with SPDT contacts for an external alarm permits signalling the alarm state at a distance by means of a siren or warning light.

A diverter (fig.2a .9) on the facia permits two modes of operation for the alarm system:

ON : – Valve closed or fan in operation;
– Visual alarm in operation;
– Internal buzzer alarm in operation;
– External alarm in operation.

OFF : – Valve closed or fan in operation;
– Visual alarm in operation;
– Internal buzzer alarm switched off;
– External alarm switched off.

The OFF position permits carrying out the necessary checks while keeping the plant in a state of maximum safety but avoiding the annoyance of audible alarms.

ALARM DELAY

By means of the Alarm Delay trimmer (fig.2a .7) it is possible to set the period (5 to 30 seconds) for which the local alarm state has to persist before the central unit goes into the general alarm state. This is to prevent a temporary concentration of gas above the threshold level setting of the general alarm unnecessarily.

ALARM RETENTION AND RESETTING

- **Combustible gas and CO detector unit : AGS 012**
On the electronic circuit there is a switch (fig. 3) which allows the choice between two modes:
 - Without Alarm Retention mode: when the signal from the sensor falls below the alarm threshold the alarm ceases and the Alarm LED (fig.2b .13) goes out.
 - With Alarm Retention mode: even when the signal from the sensor falls below the alarm threshold the alarm continues and the Alarm LED remains lit. It is switched off when the normal (non-alarm) state is restored by means of the Reset button of the central unit AGS 013. This system makes it possible to identify which zone has entered the alarm state.
- **Fire detector unit : AGS 015**
Operates always in Alarm Retention mode since this mode is imposed by the RFI 308 sensor itself. To restore the normal state after the alarm has ceased power must be cut off from the unit for a few seconds by means of the RESET button (fig.2c .17).
- **Central unit : AGS 013**
On the electronic circuit there is a switch (fig.3a) which permits the choice of:
 - Without Alarm Retention mode: the alarm ceases when the alarm signal coming from the detector unit ceases: the Alarm LED (fig.2b .13) goes out, the internal buzzer is switched off, the external alarms relay and the operational relay return to normal positions.
 - With Alarm Retention mode: the alarm state remains even when the alarm signal coming from the detector unit ceases. To restore the normal operation the RESET button (fig.2a .8) must be pressed and this re-sets the detector units AGS 012 at the same time.

The units AGS 013 and AGS 012 are supplied with Alarm Retention mode.

SELF-DIAGNOSIS

The detector units AGS 012 and AGS 015 contain a self-diagnosing system with which they can detect and signal, by means of the Fault (fig.2 .12) and Alarm (fig.2 .13) LEDs, if any sensors are defective or incorrectly connected.

Type of fault	LED	
	Fault	Alarm
Sensor RFI 308 Not connected to one of the terminals of the sensor	⊗	
Sensors S . . . 300/301 Self-heating element of sensor broken	⊗	
No connection to terminal 1 of sensor	⊗	
No connection to terminal 2 of sensor		⊗
No connection to terminal 3 of sensor	⊗	
Connections 1 and 2 of sensor inverted	⊗	
Connections 1 and 3 of sensor inverted		
Connections 1 and 4 of sensor inverted		
Connections 2 and 3 of sensor inverted		
Connections 2 and 4 of sensor inverted		
	Fuse blown	
	Fuse blown	
	TEST does not work	
	TEST does not work	

When the ALARM LED lights, the detector unit puts the system in the alarm state.

MONITORING SENSORS

The basic component of every sensor is the sensing element, that is the device which continuously analyses the surrounding air.

- S . . 300 and S . . 301

These comprise a semiconductor element which in the presence of gas or inflammable vapours varies its electrical conductivity in proportion to the concentration of gas in the air.

This variation generates a voltage which, transmitted to the detector unit AGS 012 and appropriately amplified, is used to make the necessary interventions.

Two models are available which differ in respect of to the sensing element used and therefore the type of gas they can monitor:

- S . . 300 : Natural gas, town gas, LPG, propane
- S . . 301 : Carbon monoxide

- RFI 308

Detects the presence of fumes produced by the outbreak of fires by means of a photodiode in a "smoke chamber" and signals the alarm state to the detector unit AGS 015 by means of a signal of the On-Off type. It sets on its own the alarm level and carries out automatically the Alarm Retention. To restore normal operation once the alarm state has ceased it is sufficient to switch off the power supply for a few seconds.

CONSTRUCTION**CONTAINER RACK CRM 284**

19" container rack (DIN 41494) with an overall useful width of 84 TE (427 mm.) for Europe cards 3 units high.

Provided with fixing holes for rapid mounting on standard rack enclosures; since it is completely enclosed panel mounting in cabinets normally used for electrical equipment is also very simple. Provided with two front handgrips to facilitate installation. At the rear, protected by the back plate, are to be found: terminal blocks, power supply transformer and the connections between the various cards.

One container rack can house 1 AGS 013 unit and 12 AGS 012 or AGS 015 units.

CENTRAL UNIT AGS 013 (fig. 2a)

Consists of a Europe card with a 31-pin male connector and an aluminium fascia 3 units high and 12 TE wide (61 mm.) wide.

DETECTOR UNIT ASG 012 (fig. 2b) AND ASG 015 (fig. 2c)

Consists of a Europe card with a 31-pin male connector and an aluminium fascia 3 units high and 6 TE (30 mm.) wide.

ELECTRICAL SYSTEM

The system can be powered by 220/240 V ac and/or 12 V dc. This permits using a back-up battery to keep the devices operating in case the mains supply should fail. The electrical connections are made to the appropriate terminal block on the back panel of the container rack, following carefully the wiring diagrams (fig. 6) and **observing the safety regulations in force at the time of installation.**

The minimum cross-sections of the cable cores for connecting the sensors depends on the length of the lines:

- up to 400 metres : 1 mm.²
- up to 500 metres : 1.5 mm.²

FACIA

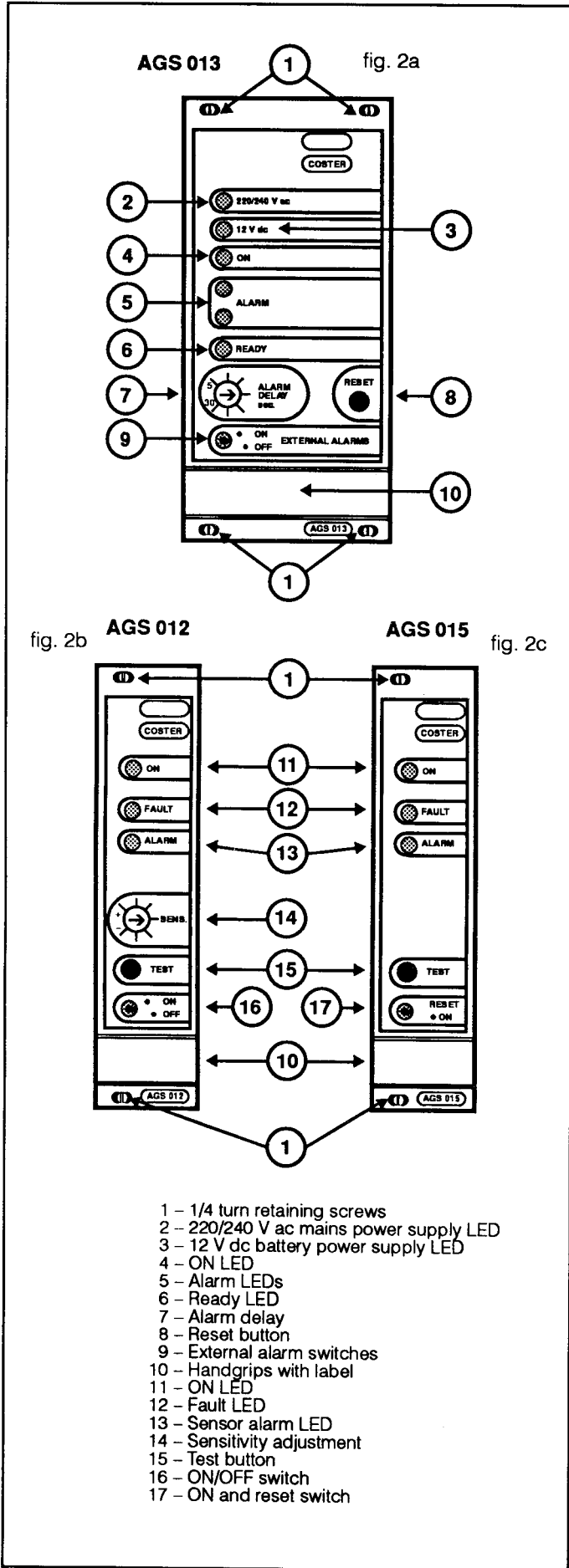

INSTALLATION

CONTAINER RACK CRM 284

The container rack complete with cards must be installed preferably in premises where personnel are always present so that, in the event of an alarm, they can take action as quickly as possible. Where this is not possible, the central unit AGS 013 can in any case be connected to remote visual and audible alarms.

If installed in locations classified as "Dangerous", it must be mounted inside electrical cabinets constructed according to regulations in force on the basis of the type of danger involved.

If it is necessary to monitor premises where the use of explosion-proof equipment is required, in such premises only sensors SAR 300 or 301 may be installed.

MONITORING SENSORS

In order to obtain good monitoring it is very important to position the sensor correctly. Its position depends on the type of gas to be monitored and its density in respect of air.

Application	Sensor	Position
Natural gas	S . 300	20 to 60 cm. from the ceiling
LPG	S . 300	20 to 60 cm. from the ground
CO	S . 301	1.5 to 2 metres from the ground or at any rate in the upper part of the room
Combustion fumes	RFI 308	On the ceiling

In central heating systems with natural gas burners the sensors must be positioned, as must all electrical equipment, at not less than 50 cm. from the ceiling; with LPG burners, at not less than 50 cm. from the floor.

TECHNICAL DATA

- Power supply:
- mains 220/240 Volt ac; 40 VA
 - back-up battery 12 Volt dc; 1.6 A
- Voltage-free output contacts:
- type of contacts SPDT
 - maximum voltage applicable 250 Volt
 - maximum capacity 1 A
- Adjustment alarm sensitivity - 5 to + 5
- Adjustment alarm delay 5 to 30 s
- Alarm threshold:
- combustible gas 0.3% gas in air
 - CO 0.05% CO in air
- Ambient temperature:
- operation 0 to 45 °C
 - storage - 20 to 60 °C
- Protection IP 20

TESTING

CENTRAL UNIT AGS 013

- Switch on the system: power supply LEDs lit (fig.2a .2 and/or .3).
- After 1.5 to 2 minutes the system is ready to function: "Ready" LED (fig.2a .6) lit.
- Position Alarm Delay (fig.2a .3) on minimum.
- Position diverter (fig.2a .9) on ON.

DETECTOR UNIT AGS 012

- Switches (fig.2b .16) on On, On LED (fig.2b .11) lit.
- Position Sensitivity potentiometers (fig.2b .14) on 0.
- Check that sensors are connected correctly, Fault (fig.2b .12) and Alarm (fig.2b .13) LEDs out.
- Press Test button (fig.2b .15) of 1st detector unit: Alarm LED (fig.2b .13) should light.
- After 5 seconds (alarm delay), the central unit switches on the visual (fig.2a .5) and audible alarms; activates the operational relay and the external alarms relay.
- Position the deviator (fig.2a .9) on OFF: the internal audible alarm and external alarms are switched off.
- Re-set the system by means of the "Reset" button (fig.2a .7): the alarm LEDs (fig.2a .5 and fig.2b .13) go out and the operational relay is switched off.
- Repeat the test for the other detector units.

DETECTOR UNIT AGS 015

- Power supply switch (fig.2c .17) on On: On LED (fig.2c .11) lit.
- Check that sensors are correctly connected: Fault (fig.2b .12) and Alarm (fig.2b .13) LEDs out.
- Press Test button (fig.2b .15) of 1st detector unit: Alarm LED (fig.2b .13) should light.
- After 5 seconds (alarm delay), the central unit switches on the alarm LEDs (fig.2a .5) and the internal buzzer and activates the operational relay and the external alarms relay.
- Position the deviator (fig.2a .9) on OFF: the internal audible alarm and the external alarms are switched off.
- Re-set the detector unit by switching the power supply switch to Reset (fig.2c .17) for a few seconds: the alarm LED (fig.2c .13) goes out.
- Re-set the central unit by pressing the Reset button (fig.2a .9): the alarm LED (fig.2a .5) goes out and the operational relay is switched off.
- Repeat the test for the other detector units.

This method of testing is sufficient to ensure that the system is working properly.

If it is desired to be more scrupulous, in order to put the AGS 012 units in the alarm state it is necessary to simulate the presence of gas by releasing gas from an ordinary cigarette lighter near the sensor. To put the AGS 015 units in the alarm state smoke must be simulated by means of a cigarette held below sensor RFI 308.

ALARM RETENTION SWITCH

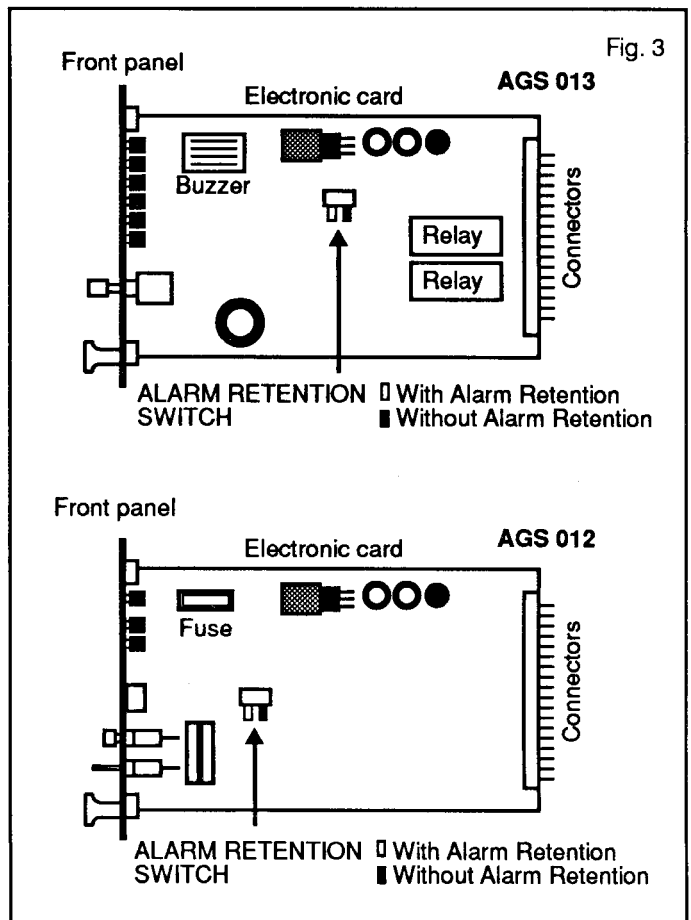

OVERALL DIMENSIONS

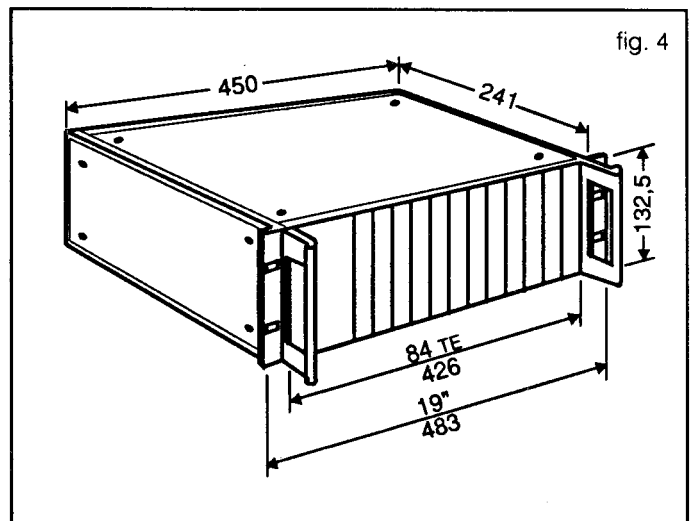

CUT - OUT PANEL MOUNTING

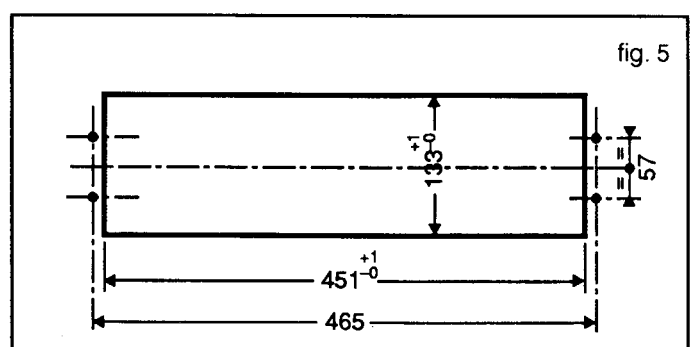

WIRING DIAGRAMS

fig. 6

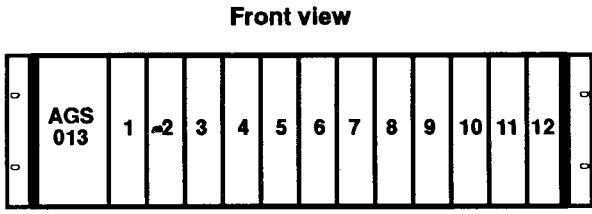

Detector unit
AGS 012 o AGS 015

Correspondence of connections between sensors and detector units

Terminal block S1

Unit	Terminals
n° 1	1-2-3-4
n° 2	5-6-7-8
n° 3	9-10-11-12

Terminal block S2

Unit	Terminals
n° 4	1-2-3-4
n° 5	5-6-7-8
n° 6	9-10-11-12

Terminal block S3

Unit	Terminals
n° 7	1-2-3-4
n° 8	5-6-7-8
n° 9	9-10-11-12

Terminal block S4

Unit	Terminals
n° 10	1-2-3-4
n° 11	5-6-7-8
n° 12	9-10-11-12

Connection sensors S.. 300 - 301

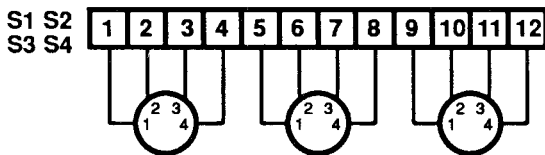

Connection RFI 309 sensors

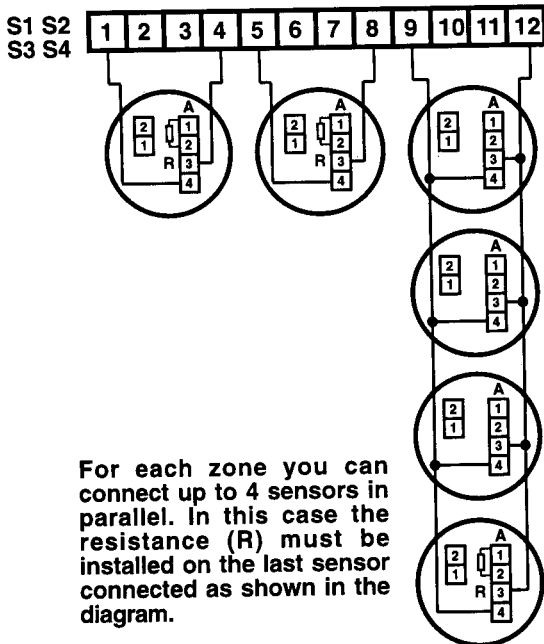

For each zone you can connect up to 4 sensors in parallel. In this case the resistance (R) must be installed on the last sensor connected as shown in the diagram.

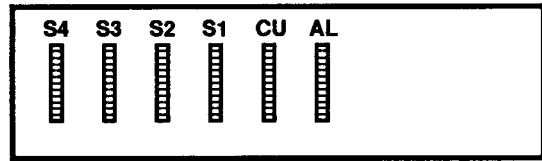

Position terminals

Power supply

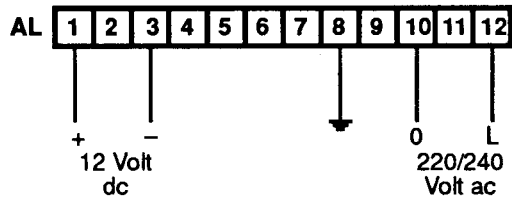

Outputs

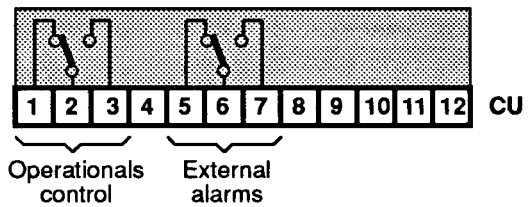

Position contacts

Normal:
2-1 closed ; 2-3 open
6-5 closed ; 6-7 open

Alarm state:
2-1 open ; 2-3 closed
6-5 open ; 6-7 closed

Control valve N.C.

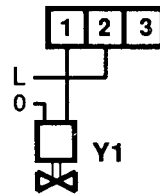

Control valve N.O.

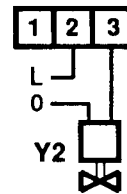

Control fan

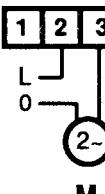

External alarms

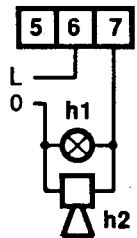

- L - Line
- 0 - Neutral
- AL - Power supply terminal block
- CU - Controls terminal block
- S1, S2, S3, S4 - Sensors terminal block
- h1, h2 - External alarms
- Y1 - Gas solenoid valve N.C.
- Y2 - Gas solenoid valve N.O.
- M - Aeration fan