

Caratteristiche Tecniche

- 1 **TERMOMETRO** (Temperatura acqua)
- 2 **MANOMETRO** (Pressione gas)
- 3 **VALVOLA PORTAMANOMETRO**
- 4 **DISPOSITIVO PER CONTROLLO LIVELLO LIQUIDO**
- 5 **VALVOLA DI INTERCETTAZIONE** (Chiusura manuale)
- 6 **ENTRATA ACQUA** (Attacco flangiato)
- 7 **VALVOLA DI SPURGO** (Impurità del gas)
- 8 **FILTRO A CESTELLO**
- 9 **VALVOLA DI INTERCETTAZIONE** (Chiusura pneumatica e manuale)
- 10 **ATTUATORE PNEUMATICO**
- 11 **USCITA ACQUA** (Attacco flangiato)

FEATURES

- 1 **THERMOMETER** (WATER TEMPERATURE)
- 2 **PRESSURE-GAUGE** (GAS PRESSURE)
- 3 **PRESSURE-GAUGE HOLDER VALVE**
- 4 **LIQUID-LEVEL CONTROL DEVICE**
- 5 **ON/OFF VALVE** (MANUAL CLOSING)
- 6 **WATER INLET** (FLANGED PIPE)
- 7 **BLEEDER** (GAS IMPURITIES)
- 8 **BASKET STRAINER**
- 9 **ON/OFF VALVE** (PNEUMATIC/MANUAL CLOSING)
- 10 **PNEUMATIC ACTUATOR**
- 11 **WATER OUTLET** (FLANGED PIPE)

Il vaporizzatore per G.P.L. 3L.P. GAS "LEVEL CONTROL" rappresenta un'innovazione nel campo delle apparecchiature per la vaporizzazione del G.P.L.; collegato in fase liquida al serbatoio di stoccaggio (vedi schema di funzionamento) permette, **unico nel suo genere**, il controllo del livello della fase liquida al suo interno in modo elettronico e consente la gestione dei segnali in uscita (in sicurezza intrinseca) a seconda delle esigenze.

Il suddetto dispositivo (Pos.4) rileva istante per istante l'altezza del liquido presente nel vaporizzatore, ed al superamento della soglia limite per la quale lo stesso è dimensionato, invia in tempo reale il segnale per la chiusura della valvola di adduzione (pneumatica o elettrica) G.P.L. in fase liquida (Pos. 9 - 10).

Sono possibili anche collegamenti a spie visive e/o acustiche di preallarme, e controllo tramite P.C..

I vaporizzatori sono interamente costruiti secondo le normative vigenti e testati uno ad uno a pressione di 27 bar (tubazione gas e acqua); la produzione di serie (vedi tabelle A e B) è ampliabile a richiesta e copre qualsiasi tipo di capacità necessaria.

ANNI DI PROGETTAZIONI E INSTALLAZIONI DI IMPIANTI "CHIAVI IN MANO" PER IL G.P.L. IN TUTTO IL MONDO SONO LA N/S GARANZIA DI AFFIDABILITA' E SICUREZZA, E IL VAPORIZZATORE "LEVEL CONTROL" SARÀ LA V/S TRANQUILLITÀ DI POSSEDERE FINALMENTE UN'APPARECCHIATURA SICURA.

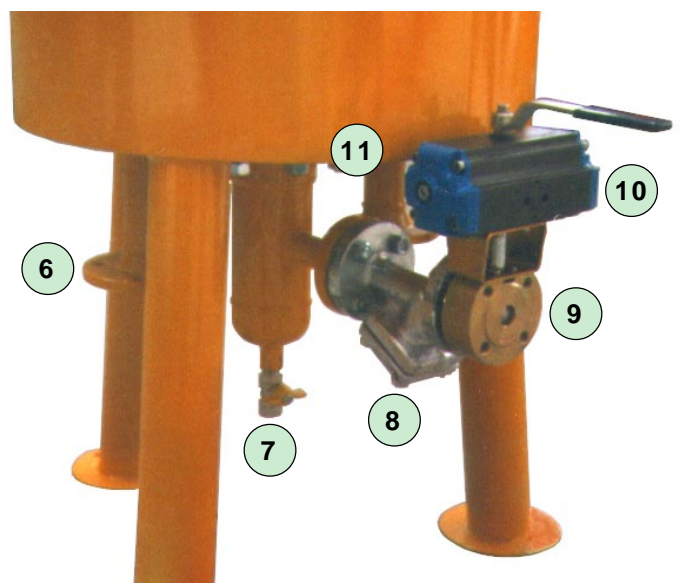

Schema di funzionamento

OPERATION DIAGRAM

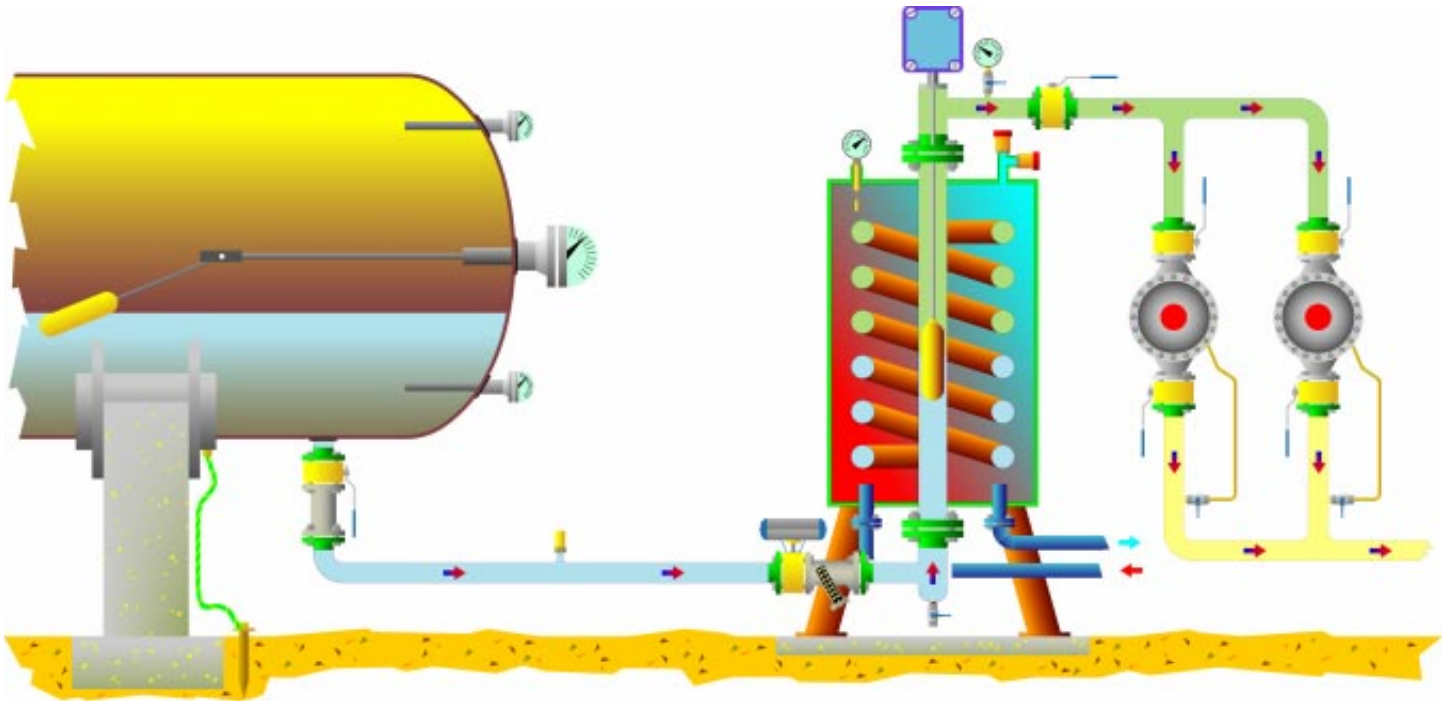

3L.P. GAS "LEVEL CONTROL" LPG VAPORIZER REPRESENT A STEP AHEAD IN THE MANUFACTURING OF LPG VAPORIZATION SYSTEMS; THE ONLY SYSTEM OF ITS KIND, IT ALLOWS ELECTRONIC AND INTERNAL LIQUID-PHASE-LEVEL CONTROL AND OUTPUT SIGNALS MANAGEMENT (INTRINSIC PROTECTION METHOD) ON A PERNEED BASIS, THROUGH ITS CONNECTION TO THE STORAGE TANK'S LIQUID-PHASE (SEE OPERATION DIAGRAM).

THE ABOVE MENTIONED DEVICE (SEE DETAIL # 4) PROVIDES MOMENT-BY-MOMENT LIQUID-LEVEL DEPTH MEASUREMENT INSIDE THE VAPORIZER, AND SENDS A REAL TIME VALVE-SHUTOFF SIGNAL TO THE LPG LIQUID-PHASE SUCTION VALVE (ELECTRICAL OR PNEUMATIC, SEE DETAILS # 9-10) WHENEVER THE SYSTEM THRESHOLD IS EXCEEDED. VISUAL AND/OR ACOUSTIC PREALARM SYSTEMS ARE AVAILABLE, AS WELL AS A PLC. ALL VAPORIZERS ARE ENTIRELY BUILT IN ACCORDANCE WITH APPLICABLE LAWS AND ARE INDIVIDUALLY TESTED AT 27 BARS (WATER AND GAS PIPES); SERIES PRODUCTION (SEE TABLES A & B) IS SUBJECT TO EXPANSION TO SUIT CUSTOMER DEMAND AND MEETS ANY TYPE OF REQUIRED CAPACITY.

YEARS OF WORLDWIDE DESIGN & INSTALLATION OF "TURNKEY" LPG SYSTEMS ARE OUR WARRANTY OF RELIABILITY & SAFETY; OUR "LEVEL CONTROL" VAPORIZERS WILL GRANT YOU THE PEACE OF MIND THAT COMES WITH OWNING SAFE EQUIPMENT AT LAST.



WATER VAPORIZERS - PRODUCTION PLAN

| STANDARD PRODUCTION | CAPACITY Kg/h | L.P.G. INLET Ø | L.P.G. OUTLET Ø |
|---------------------|---------------|----------------|-----------------|
| | 50 | 1/2" | 1" |
| | 100 | 1/2" | 1" |
| | 200 | 1/2" | 1" |
| | 300 | 3/4" | 1¼" |
| | 500 | 1" | 1½" |

ALL SIZES OF CAPACITY ARE AVAILABLE ON REQUEST

ELECTRIC VAPORIZERS - PRODUCTION PLAN

| STANDARD PRODUCTION | CAPACITY Kg/h | L.P.G. INLET Ø | L.P.G. OUTLET Ø | ABSORBED POWER Kw |
|---------------------|---------------|----------------|-----------------|-------------------|
| | 35 | 1/2" | 1" | 4 |
| | 50 | 1/2" | 1" | 8 |
| | 100 | 1/2" | 1" | 16 |
| | 300 | 1" | 1½" | 32 |

DIFFERENT SIZES OF CAPACITY ARE AVAILABLE ON REQUEST

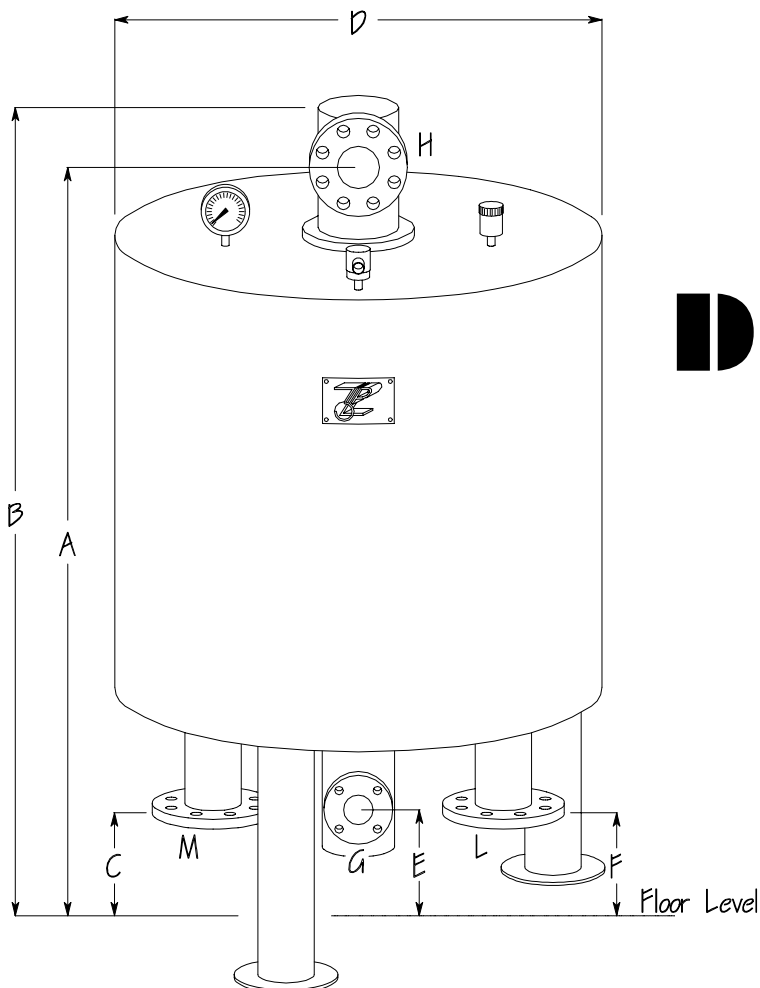

DIMENSIONS

- A = 1975 mm.
- B = 2100 mm.
- C = 430 mm.
- D = 1020 mm.
- E = 400 mm.
- F = 430 mm.
- G = ND 32 (gas inlet)
- H = ND 65 (gas outlet)
- L = ND 50 (water outlet)
- M = ND 50 (water inlet)

LEVEL CONTROL L.P.G. WATER VAPORIZER

YEAR 1999
POWER 1500 Kg/h
MANUFACTURER # 119/99 & 132/99

SUPPLIER CERTIFICATE

Law n°46 5 - 03 - 1990.

REGULATIONS FOR PLANT SAFETY.

DPR 6 - 12 - 1991 Execution of regulations.

The materials constituent the vaporizers, are in conformity to feature request. In particular:

GAS CIRCUIT - Execution NP40

The pipes, plate, flanges specials parts, are in conformity to use class, with test certificate.

The weldings (only electric), are made from skilled welder, with quality electrode use.

The test are made with water pressure 27 Bar (18 Bar maximum working pressure +50%) with positive issue.

WATER CIRCUIT - Pressing at 3 Bar, with positive issue.

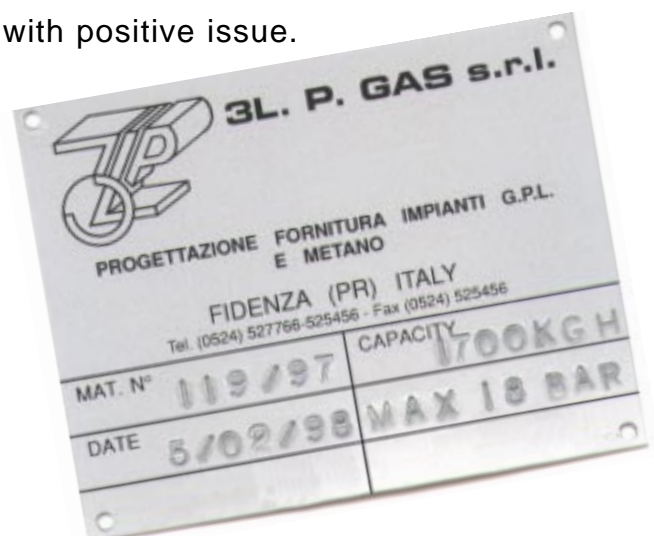

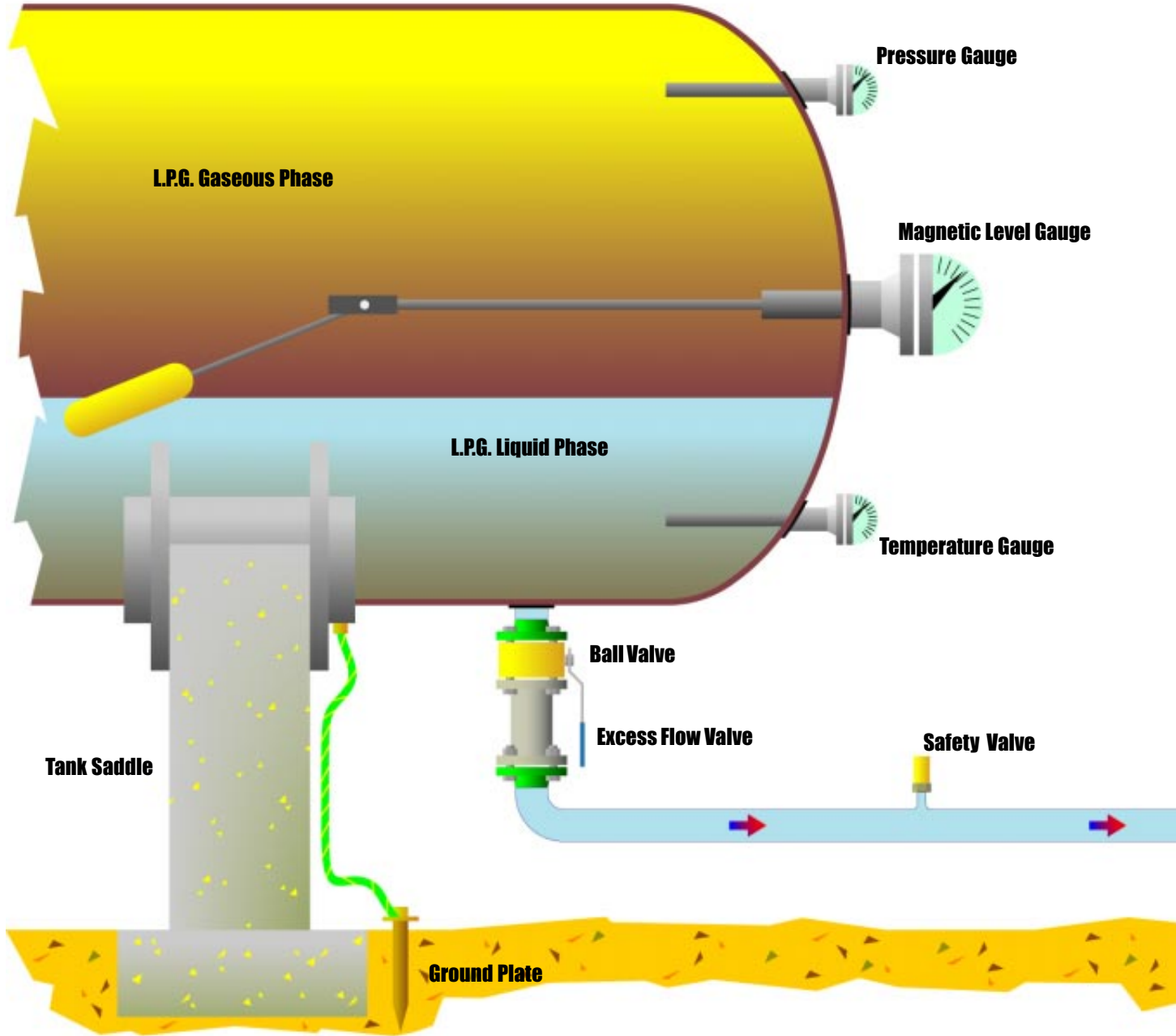

OPERATION

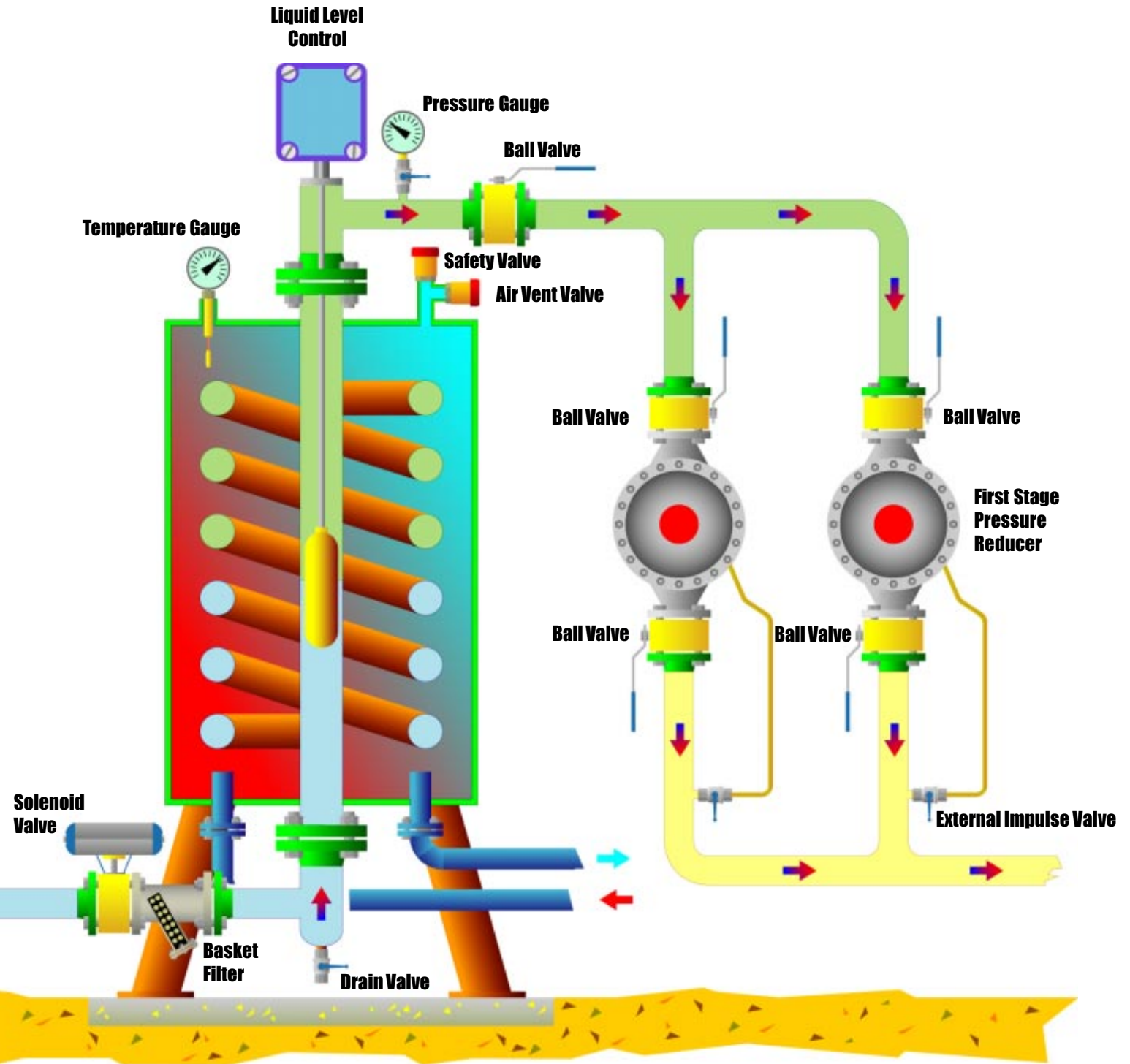

DIAGRAM



3 L.P. GAS LEVEL CONTROL VAPORIZER

The 3 L.P. GAS "LEVEL CONTROL" Vaporizer are basically made of 3 distinct chambers:

- The central one for the L.P.G. passage (built with API 5L Gr.B pipes sch.40);
- The intermediate having the hot water container purpose;
- The external one used as a thermal insulation.

The L.P.G. pipeline's test is made with 27 bar of pressure (1,5 time more than max working pressure = 18 bar). The heating surface design give You the required capacity: 50 - 100 - 150 - 200 Kg/h for the standard electric versions and 50 - 100 - 200 - 300- 400 - 500 Kg/h for the hot water types. More powerfull vaporizers can be built on request.

Each produced "level control" vaporizer includes, as a absolute news on this apparatus field, a special electronic device wich feel in real time the liquid level inside vaporizer. The sensor works on intrinsical safety way and all other electrical parts are explosion proof made. The a.m. sensor grants You (unique of it's kind) in case of dangerous situations, the immediate and complete fluid block and the consequent impossibility to find the liquid on the outlet line!

The differences between the "level control" vaporizers and the others on market are mainly based upon this safety system, which oppositely to the normal types is not based on the floater action (that goes up when the liquid level is too high, and mechanically, using the force of the liquid weight, move a leverage which close the "clapet" valve).

As easily imaginable, a part of liquid, using the a.m. old solution can goes on the main line; first of all because, before the liquid arrival at the floater level, a part of vapour/liquid mix already passed the safety zone. This mean that a part of liquid will be inside the main line when the valve close !!! You can imagine the results You'll find on the utilization point in this case (1 part of L.P.G. liquid volume becomes 270 parts of vapour!!!!!!)

The solution used to solve this extremely dangerous trouble by the vaporizers manufacturer are:

- a) install a shut-off valve operated by thermostat at the end of the main line (both always out of supply price)
- b) install a solenoid valve at the inlet operated by a thermostat placed on the water circuit (both always out of supply price)

The a.m. solutions could be satisfactory thinking to avoid troubles to the utilizators, but there are some points not solved:

- on the a) case You've got to stop all works and machinaries, drain perfectly all the line startig from vaporizer untill the end loosing a lot of time and money (factory stop etc.)
- the b) case is even worst than the a) one, because nobody can guess if the sensor will be quick enough to feel the danger (consider that the water temperature is always related to two variables: pressure and gas temeperature at the outlet).

The vaporizer furniture include also:

- SOLENOID OR PNEUMATIC VALVE
- ELECTRIC PANEL including : intrinsically safety relay, electromagnetic switch, terminal board, working status lamps (*electric type*)
- EXPLOSION PROOF RESISTENCES (*electric type*)
- EXPLOSION PROOF BOX (*electric type*)
- CONDUIT HOSES (*electric type*)
- WORKING STATUS LAMPS
- MIN. TEMPERATURE ALARM (*electric type*)
- ELECTRONIC LEVEL CONTROL SYSTEM
- SAFETY VALVE gas phase
- SAFETY VALVE water phase
- PRESSURE GAUGE
- THERMOMETER
- BALL VALVES tropical-galvanized, "fire safe" type NP40 inlet and outlet gas phase
- BALL VALVES water type
- DRAIN SYSTEM
- BASKET FILTER
- N° 3 THERMOSTATS (2 adjustable + 1 fixed) (*electric type*)

SHUT - OFF SYSTEM:

The "LEVEL CONTROL" Vaporizer are made with two different shut-off system: pneumatic or with explosion proof solenoid valve.

The solenoid valve, placed on the liquid phase inlet, is standard mounted on the vaporizers 50 and 100 Kg/h electric and hot water version, (respectively $\varnothing \frac{1}{2}$ " e $\varnothing \frac{3}{4}$ ") on request for higher capacity.

Electronic sensors inside the L.P.G. pipe, when the liquid level reach the dangerous point, becomes excited and sends the immediate signal to the solenoid valve wich stop the inlet.

The same shut-off system is also available with a pneumatic valve instead the solenoid one. Both solutions working in "positive safety" (no tension or no air close the valve).

IMPORTANT: The electronic sensor must works on "intrinsically safety" way, this mean that the "electronic relay" (included on the scope of supply) is made to be placed out of the explosion proof site.

ELECTRIC RESISTANCE CHARACTERISTICS:

- Available: 220 - 380 - 415 V.
- Explosion proof made (with certificate) IP 54 EExd II CT3

Electromagnetic Level Indicators

EMPLOYMENT

The electromagnetic level indicators have been designed to check the level of a fluid as water, gas oil, solvents, acids, etc. contained in a tank and send an electric signal of min and max level alarm on the control board.

They are normally employed in the oleodynamics, lubrication, plant engineering, fluid stocking, industrial vehicles, electricity generation, etc.

COMPONENTS

Fastening flange in anodized aluminium, brass bar, NBR expanded resin float or in stainless steel.

TECHNICAL DATA:

| | |
|-------------------------------|----------------------|
| Commutated Power | 60 W |
| Commutated Power | 60 VA |
| Max voltage | ~ 220 V-50 Hz |
| Max intensity of current | 0.8 A (resistive) |
| Idle contact (without fluid) | "NC" |
| Open contacts capacity | 0.6 pF |
| Contact insulation resistance | 10 ¹⁰ ohm |
| Electrical connection | PG9-DIN 43650 |
| Electrical protection | IP65-DIN 40050 |
| Working temperature | -10 +80°C |
| Gasket Viton max temperature | 130°C |
| Fastening | Vertical |
| Max slope | 15° |
| Maximum pressure | 20 bar |
| Fluid specific weight | ³ 0.7 |
| Fluid viscosity | 150 cSt. |

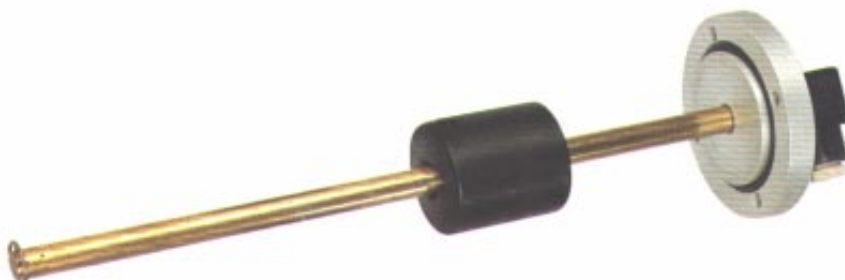

Type LM1GA500

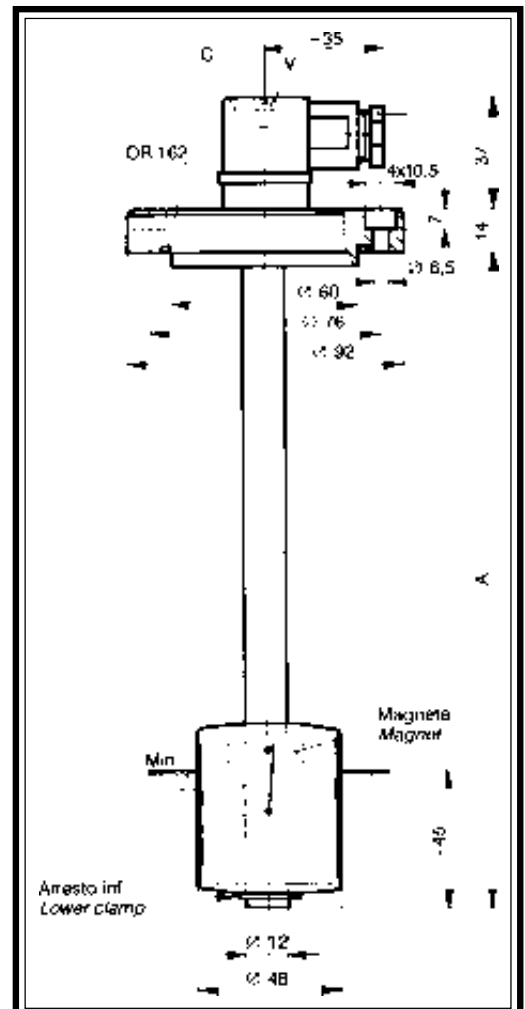



Via Bologna 14 - 43036 FIDENZA (PR) - ITALY
Phone +39 0524 527766 Fax +39 0524 525456
<http://www.3lpgas.com> e-mail: 3lpgas@polaris.it